



Price Index



31 Widths
10 Bending Radii



Extension links for variable widths



KMA mounting brackets available



KMA steel mounting brackets available

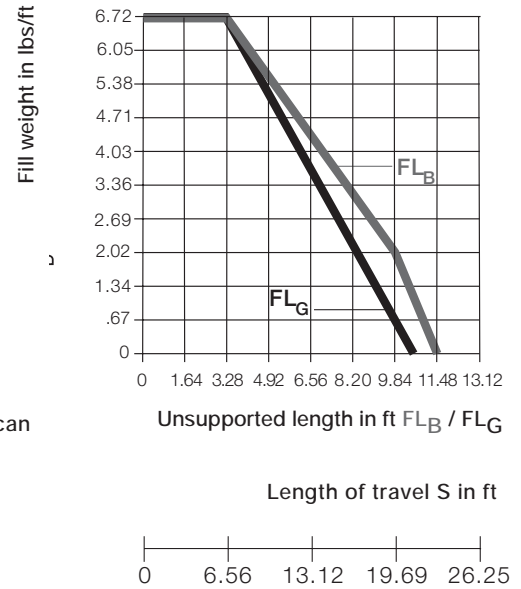
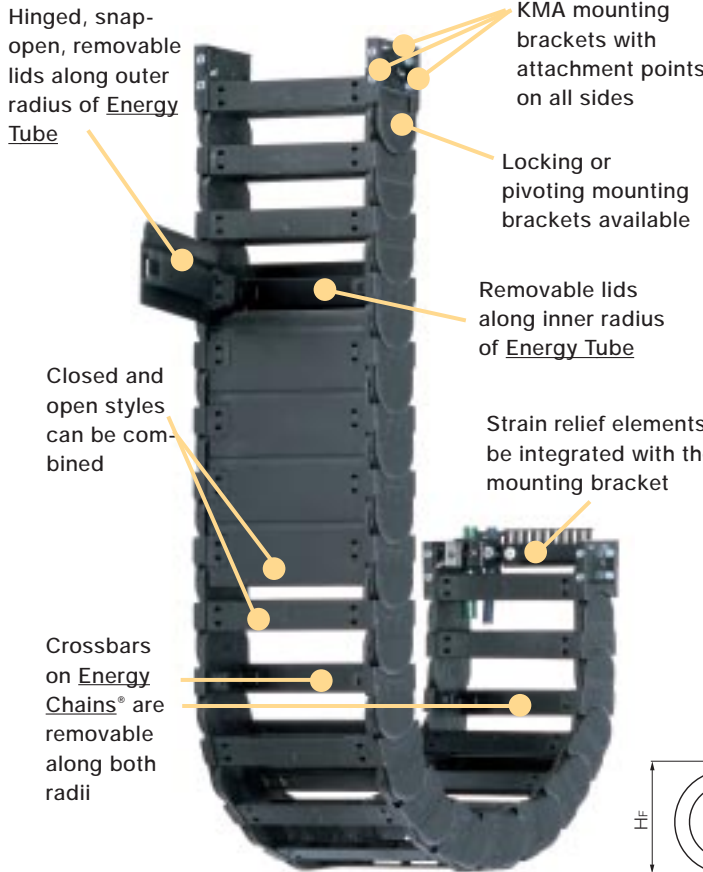

Ununsupported length
 ● FL_B = unsupported with permitted sag
 ● FL_G = unsupported with straight upper run

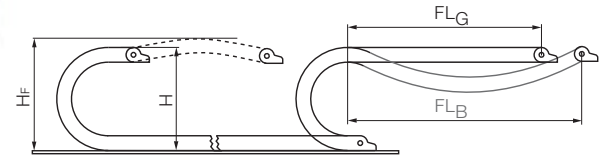

Product range

Inner Widths (Bi) inches (mm):	1.97 - 15.75 (50 - 400)
Bending Radii (R) inches (mm):	2.48 (63), 2.95 (75), 3.94 (100), 4.92 (125), 5.91 (150), 6.89 (175), 7.87 (200), 8.66 (220), 9.84 (250), 11.81 (300)
Pitch:	2.20 (56 mm/link) = 5.49 links/ft (18 links/m) 39.6 (1008 mm)



Ununsupported Energy Chains® ► **Design, Chapter 1**, feature positive camber over short travels. This must be accounted for when specifying the clearance height. Please refer to **Installation dimensions** for further details.

If the ununsupported length is exceeded, the Energy Chain®/Tube must glide on itself. This requires a guide trough ► **Design, Chapter 1** or incorporation of igus® exclusive AUTO-GLIDE System guide elements, which are available for this chain series ► **AUTO-GLIDE System, Chapter 9**

Other Installation Methods:

Vertical, hanging	= max 230 ft (70 m)
Vertical, standing, ununsupported*	= max 16.4 ft (5 m)
Side-mounted, ununsupported	= max 6.56 ft (2 m)
Rotary	= requires further calculation

*With support, this distance can be greater. Call igus for details.

● Long travel Max: 656 ft. (200 m)



When to use the Series 2828/2928/R7728:

- If subject to high torsional or shearing forces
- If a side-mounted chain/tube with long ununsupported lengths is required
- If subject to very damp environments consistently



When not to use the Series 2828/2928/R7728:

- If a quieter version is required ► Series 280/ 290/ R770, **Chapter 6**
- If a simpler system is sufficient ► Series 28/ 29/ R77, **Classic Carrier Catalog**

- Accessories for ► **Guide Troughs, Chapter 9** ► **Design, Chapter 1**



Series 2828/2928/R7728 "E4/4"



2828
2928
R7728

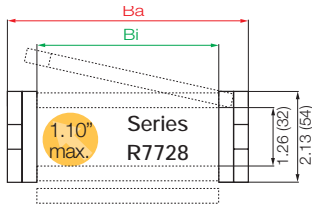
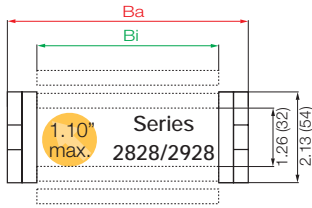

For crossbar selection please visit www.igus.com and use the "E-Chain Helper"

Extender crossbar for large diameter hoses, see following page.



Supplement part number with required radius for example, 2828-07-150-0

Part No.	Bi	Ba ²
2828/ 2928/ 7728-05*	1.97 (50)	2.87 (73)
2828/ 2928-06	2.68 (68)	3.58 (91)
2828/ 2928/ 7728-07	2.95 (75)	3.86 (98)
2828/ 2928-087	3.43 (87)	4.25 (108)
2828/ 2928/ 7728-10	3.94 (100)	4.84 (123)
2828/ 2928/ 7728-11	4.25 (108)	5.16 (131)
2828/ 2928-112	4.41 (112)	5.35 (136)
2828/ 2928/ 7728-12	4.92 (125)	5.83 (148)
2828/ 2928-137	5.39 (137)	6.34 (161)
2828/ 2928/ 7728-15	5.91 (150)	6.81 (173)
2828/ 2928-162	6.38 (162)	7.32 (186)
2828/ 2928/ 7728-17	6.61 (168)	7.52 (191)
2828/ 2928-18	6.89 (175)	7.80 (198)
2828/ 2928-187	7.36 (187)	8.31 (211)
2828/ 2928/ 7728-20	7.87 (200)	8.78 (223)
2828/ 2928-212	8.35 (212)	9.29 (236)
2828/ 2928-23	8.86 (225)	9.76 (248)
2828/ 2928-237	9.33 (237)	10.28 (261)
2828/ 2928/ 7728-25	9.84 (250)	10.75 (273)
2828/ 2928-262	10.31 (262)	11.26 (286)
2828/ 2928-28	10.83 (275)	11.73 (298)
2828/ 2928-29	11.30 (287)	12.24 (311)
2828/ 2928/ 7728-30	11.81(300)	12.72 (323)
2828/ 2928-312	12.28 (312)	13.23 (336)
2828/ 2928-325	12.79 (325)	13.70 (348)
2828/ 2928-337	13.27 (337)	14.21 (361)
2828/ 2928-350	13.78 (350)	14.69 (373)
2828/ 2928-362	14.25 (362)	15.20 (386)
2828/ 2928-375	14.76 (375)	15.67 (398)
2828/ 2928-387	15.24 (387)	16.18 (411)
2828/ 2928-400	15.75 (400)	16.65 (423)

Bending Radii for ALL Widths

- 2.48 (063)**
- 2.95 (075)**
- 3.94 (100)**
- 4.92 (125)
- 5.91 (150)
- 6.89 (175)
- 7.87 (200)
- 8.66 (220)
- 9.84 (250)
- 11.81 (300)

* Removable lid only, no hinged option

** Not available for R7728

For wider chains, see following pages

PDF: www.igus.com/echainpdf.asp
 Specs/CAD/RFO: www.igus.com/echain.asp
 RoHS info: www.igus.com/RoHS.asp

Price Index



Series 2828, Energy Chain (with crossbars every link)

Select Energy Chains® with crossbars every link when using rigid hydraulic hoses or if an application is particularly demanding.



Standard Price Index



Series 2928, Energy Chain (with crossbars every other link)

This design is the **standard** Energy Chain® for this size range. For almost all applications, the Series 2928 offers the easiest assembly and best stability for the price.



Price Index



Series R7728, Energy Tube (fully enclosed)

Energy Tubes offer excellent cable and hose protection against dirt, debris and other contaminants, as well as hot chips. This design offers cable and hose accessibility along both radii. Lids along the entire inner radius are completely removable. Lids along the entire outer radius are single-sided snap-open with a hinge on the other side to keep them attached to the chain, or completely removable.



Installation Dimensions

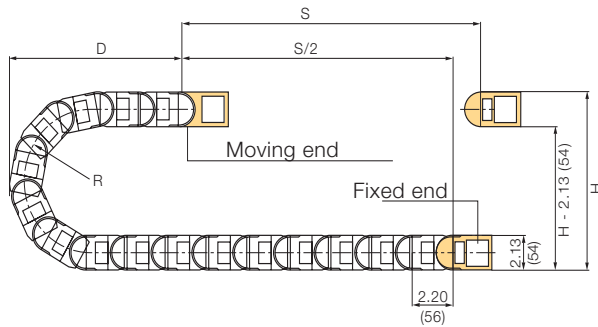

Pitch: = 2.20 (56 mm) per link
 Link per ft (m): = 5.49 (18)
 Total travel: = S
 Chain length: = $\frac{S}{2} + K$

R	2.48 (063)	2.95 (075)	3.94 (100)	4.92 (125)	5.91 (150)
H* _{4,20} ⁰	7.09 (180)	8.07 (205)	10.04 (255)	12.01 (305)	13.98 (355)
D	5.12 (130)	5.91 (150)	6.89 (175)	7.87 (200)	8.86 (225)
K	13.39 (340)	14.96 (380)	18.31(465)	21.65 (550)	24.41 (620)

R	6.89 (175)	7.87 (200)	8.66 (220)	9.84 (250)	11.81 (300)
H* _{4,20} ⁰	15.94 (405)	17.91 (455)	19.49 (495)	21.85 (555)	25.79 (655)
D	9.84 (250)	10.83 (275)	11.61 (295)	12.80 (325)	14.76 (375)
K	27.56 (700)	30.70 (780)	33.46 (850)	37.01 (940)	43.70 (1110)

* The required clearance height is HF = H + 1.57 (40) with 1.34 (2 kg/m) fill weight. Please consult igus® if space is particularly restricted.

Extension Link



The extension link has been developed for applications in which particularly high fill weights necessitate extremely wide Energy Chains®. The extension link design allows virtually limitless side-by-side attachment of chains. In addition, the unsupported length of a chain can be increased. Using extension links also allows for additional fill weights.

Extension links can be used with Energy Chains®, Energy Tubes or a combination of chains and tubes. They are equally suitable for unsupported applications and gliding applications in a guide trough.

Energy Chains® with extension links are attached with KMA mounting brackets or steel mounting brackets. We strongly recommend on-site consultation with an igus technician for individual advice regarding mounting brackets, guide troughs and other design details.

- Chain widths up to 118" (3000 mm) can be achieved

- Also available as Energy Tube



All nominal widths from the preceding page are available in all combinations.

Part number example for Energy Chain®
2828-10/20/10-200-0

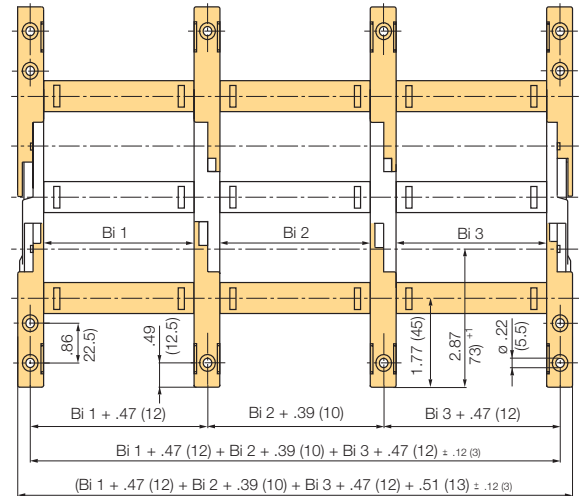

Extender Crossbars

The extender crossbars were developed specifically for applications in which a hose or large diameter cable must be guided carefully. It is intended for hoses and cables with a maximum outer diameter of 11.81 (300 mm). The extender crossbar can be placed either along the outer or inner radius. In most applications, the inner radius is preferred. However, the chain/tube cannot glide on itself in this case. If gliding operation is required, the crossbars are assembled along the outer radius and a special guide trough is required. The extender crossbar can either be attached to the side links directly or can be used in combination with two standard snap-open crossbars.

Part No.	Max Ø Hose	Style	Installation Side Link	Combined with Snap-Open Crossbars
385-15-RHD115	By request	Round	No	Yes
385-18-RD115	By request	Round	Yes	No

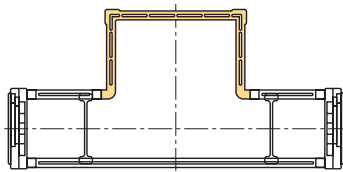

Square extender crossbar combined with standard snap-open crossbars.

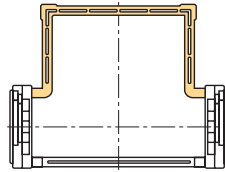

Square extender crossbars attached directly to the side link.

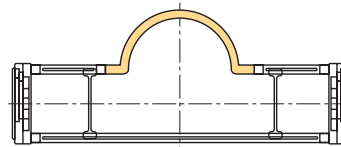

Round extender crossbar combined with standard snap-open crossbars.

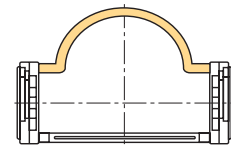

Round extender crossbar attached directly to the side link.

Consult igus® for your extender crossbar applications. We are happy to assist you with your design layout.

Hinged Crossbars

Typically, Energy Chain® crossbars are completely removable. In cases where it is preferable that the opening crossbars remain on the Energy Chain®, a hinged design has been developed.

4 hinged crossbar options are available. Please consult igus for design assistance.

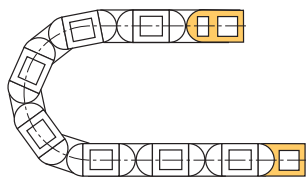

All views shown from fixed end perspective



Option 1

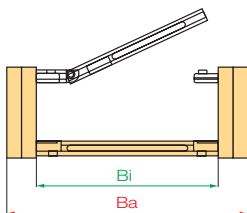

Option 2

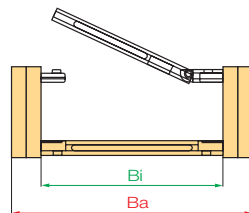

Option 3

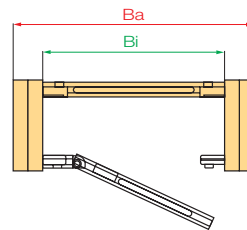

Option 4

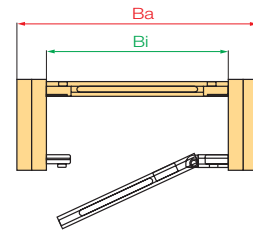

Click Here for
Specs &
CAD Files

PDF: www.igus.com/echainpdf.asp
Specs/CAD/RFO: www.igus.com/echain.asp
RoHS info: www.igus.com/RoHS.asp



Interior Separation

Option 1: separators

Separators can be placed at any point along the chain's cross-section. **igus® standard separator (Part No. 281)** offers safe stability due to its broad "foot" design, even when used with large diameter cables or hoses. If the distance needed between separators is greater than this separator's dimension, we offer the 281-14 separator.

With applications where a large number of small cables need to be individually separated, our **separator with a narrow foot (Part No. 283)** can be used (for Energy Chains only).

A **locking separator (Part No. 293)** is used in applications with very high relative humidity, such as composting plants. The increased retention force needed for these types of applications is produced by asymmetrical retention "clamps" attached to the chain's crossbar. If installing these yourself, please ensure that they are identically aligned.

The **281T separator** is used with Energy Tubes only. It clamps to the fixed radius and remains free along the other radius to facilitate lid removal.

All separators are adjustable, but may be fixed in place with spacers (chains only). Spacers are most often necessary with side-mounted applications.

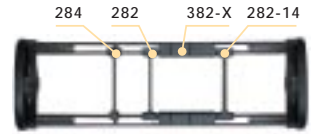

Separator 281

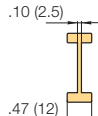

Separator Chain/Tube

Unassembled	Part No. 280
Assembled	Part No. 281



Separator 281T

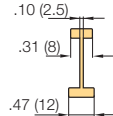

Separator (Tube Only)

Unassembled	Part No. 280T
Assembled	Part No. 281T

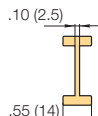

Separator Chain/Tube

Unassembled	Part No. 281-14
Assembled	Part No. 282-14

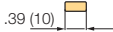

Spacer (Chain Only)

Unassembled	Part No. 381-10
Assembled	Part No. 382-10

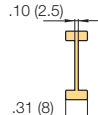

Separator (Chain Only)

Unassembled	Part No. 283
Assembled	Part No. 284



Spacer (Chain Only)

Unassembled	Part No. 381-15
Assembled	Part No. 382-15



Separator 293

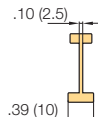

Locking Separator (Chain Only)

Unassembled	Part No. 293
Assembled	Part No. 294



Spacer (Chain Only)

Unassembled	Part No. 381-20
Assembled	Part No. 382-20



Note:

The available inner height is decreased by .08 (2 mm) per spacer, (for example, if one spacer is placed on each side of a separator, the overall inner height is reduced by .16 (4 mm). In order to avoid this, place the spacers on the outside of the opening crossbar.



Series 2828/2928/R7728 "E4/4"



2828
2928
R7728

Option 2: shelves

Energy Chains® and Energy Tubes can be subdivided both vertically and horizontally using the various interior separation elements.

Side plates, separators and shelves form the basic pattern of a shelf system. Shelves of various widths can be arranged at 5 different heights in .28 (7 mm) increments ► **Design, Chapter 1** for layout recommendations. If open, slotted separators are used, only the middle slot is available for shelves.

For special applications, a separator with an integrated injection-molded shelf 2.26 or 1.77 (57.5 or 45 mm) is available.

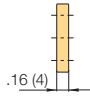
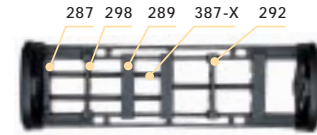

Side Plate

Unassembled Part No. 286

Assembled Part No. 287



Vertical Separator

Unassembled Part No. 288

Assembled Part No. 289

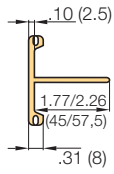

Separators w/Integrated Shelf

Unassembled Part No. 281-S-57

Assembled Part No. 282-S-57

Unassembled Part No. 281-S-45

Assembled Part No. 282-S-45



Shelves 386-XX

Width X in. (mm)	Usable Width in. (mm)	Part No. Unassembled	Part No. Assembled
.71 (18)	.39 (10)	386-18	387-18
.91 (23)	.59 (15)	386-23	387-23
.98 (25)	.67 (17)	386-25	387-25
1.10 (28)	.79 (20)	386-28	387-28
1.30 (33)	.98 (25)	386-33	387-33
1.69 (43)	1.38 (35)	386-43	387-43
1.97 (50)	1.65 (42)	386-50	387-50
2.13 (54)	1.81 (46)	386-54	387-54
2.44 (62)	2.13 (54)	386-62	387-62
2.95 (75)	2.64 (67)	386-75	387-75
3.43 (87)	3.12 (87)	386-87	387-87
3.94 (100)	3.62 (92)	386-100	387-100
4.25 (108)	3.94 (100)	386-108	387-108
4.92 (125)	4.61 (117)	386-125	387-125
5.91 (150)	5.59 (142)	386-150	387-150
6.89 (175)	6.57 (167)	386-175	387-175
7.87 (200)	7.56 (192)	386-200	387-200
8.19 (208)	7.87 (200)	386-208	387-208

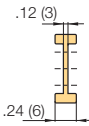

Slotted Separators

Unassembled Part No. 291

Assembled Part No. 292

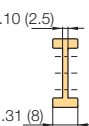

Slotted Separators, Open

Unassembled Part No. 297

Assembled Part No. 298

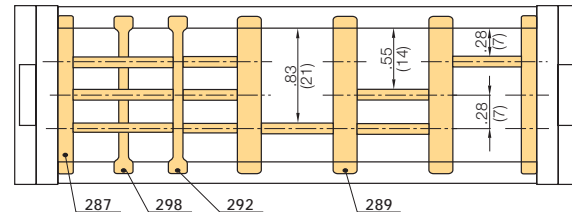
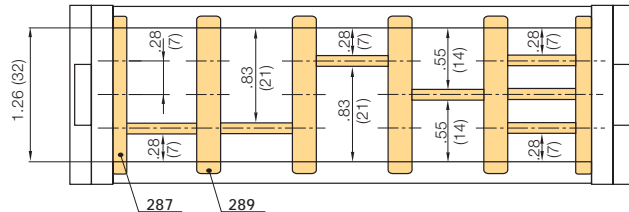

Slotted separators (Part No. 291) are used for complex subdivisions. However, they cannot be retrofitted into an existing interior separation system without removing the shelves first.



The open slotted separator (Part No. 297) can be retrofitted into an existing interior separation system without removing the shelves, as long as these shelves fit into the middle slot only.

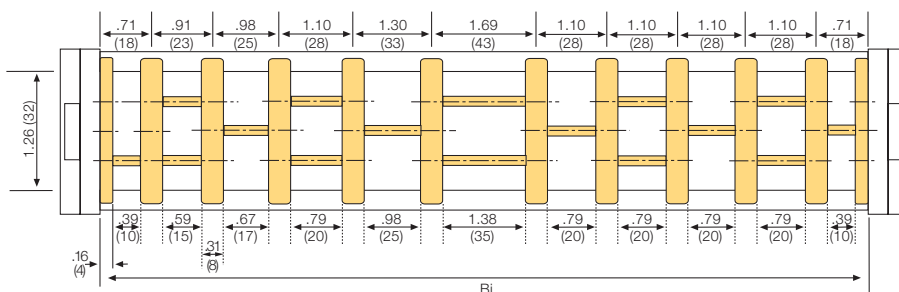
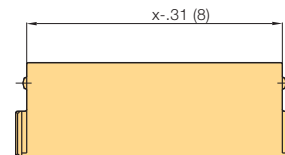

**Click Here for
Specs &
CAD Files**

PDF: www.igus.com/echainpdf.asp
Specs/CAD/RFC: www.igus.com/echain.asp
RoHS info: www.igus.com/RoHS.asp



► Page 6.163



Mounting Brackets

Option 1: pivoting

Standard

- Profile rail option
- Universal use
- Corrosion resistant
- Short and long travels
- Space-restricted conditions

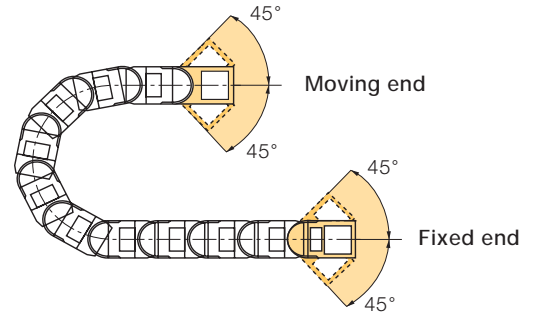

Option 2: locking

- Profile rail option
- Universal use
- Corrosion resistant
- Vertical hanging/standing travels
- Extreme accelerations

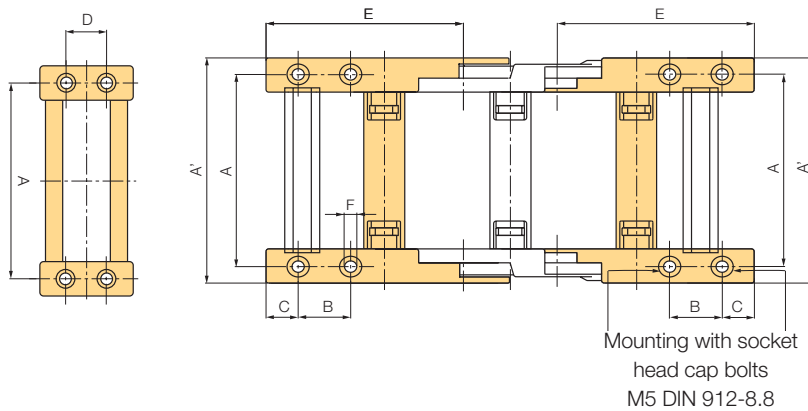
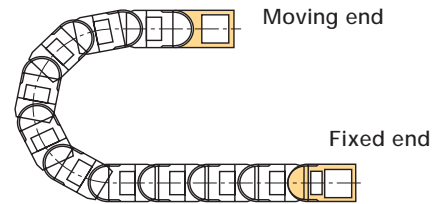

- igus tiwrap plates attached to a profile rail can be used for strain relief. Tiwraps are available as a separate part number upon request.
- ▶ Strain Relief, Chapter 10

A	A'	B	C	D	E	F	
Bi +.55 (14)	Bi +1.06 (27)	.89 (22.5)	.49 (12.5)	.87 (22)	2.87 (73)	.22 (5.5)	in. (mm)



Series 2828/2928/R7728 "E4/4"

Part No., full set
Series 2828/ 2928

282800-__-12 pivoting
292800-__-12 locking

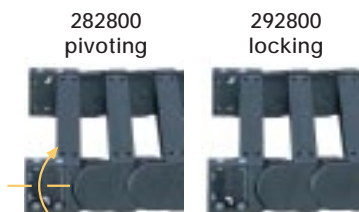

Please insert width of selected Energy Chain®.
For example, 28280-112-12 for Energy Chain® 2828/ 2928-112-__

Part No., full set, with profile rail
Series 2828/ 2928

282800-__-12P pivoting
292800-__-12P locking

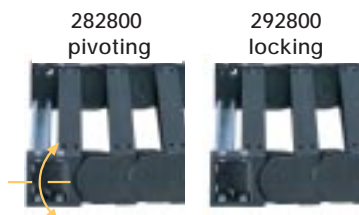

Please insert width of selected Energy Chain®.
For example, 28280-112-12P for Energy Chain® 2828/ 2928-112-__

Part No., full set
Series R7728

282800-__-12T pivoting
292800-__-12T locking

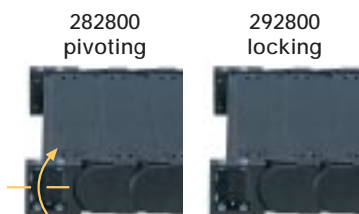

Please insert width of selected Energy Tube.
For example, 28280-112-12T for Energy Tube 7728-112-__

Part No., full set, with profile rail
Series R7728

282800-__-12TP pivoting
292800-__-12TP locking

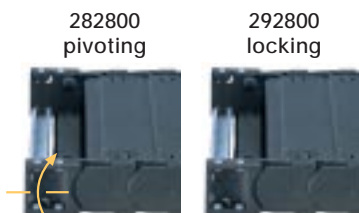

Please insert width of select Energy Tube.
For example, 28280-112-12TP for Energy Tube 7728-112-__

282800-__-12T(P)/ 292800-__-12T(P) = Full set, each part with pin/bore
282800-__-1T(P)/ 292800-__-1T(P) = Mounting bracket with bore
282800-__-2T(P)/ 292800-__-2T(P) = Mounting bracket with pin

Chain/ Tube Width	Bi
-05	1.97 (50)
-06	2.68 (68)
-07	2.95 (75)
-087	3.43 (87)
-10	3.94 (100)
-11	4.25 (108)
-112	4.41 (112)
-12	4.92 (125)
-137	5.39 (137)
-15	5.91 (150)
-162	6.38 (162)
-17	6.61 (168)
-18	6.89 (175)
-187	7.36 (187)
-20	7.87 (200)
-212	8.35 (212)
-23	8.86 (225)
-237	9.33 (237)
-25	9.84 (250)
-262	10.31 (262)
-28	10.83 (275)
-29	11.30 (287)
-30	11.81 (300)
-312	12.28 (312)
-325	12.79 (325)
-337	13.27 (337)
-350	13.78 (350)
-362	14.25 (362)
-375	14.76 (375)
-387	15.24 (387)
-400	15.75 (400)

PDF: www.igus.com/echainpdf.asp
Specs/CAD/RFQ: www.igus.com/echain.asp
RoHS info: www.igus.com/RoHS.asp

Option 3: steel

- One part for all chain widths
- Electrically conductive

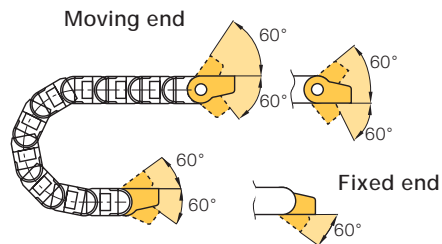
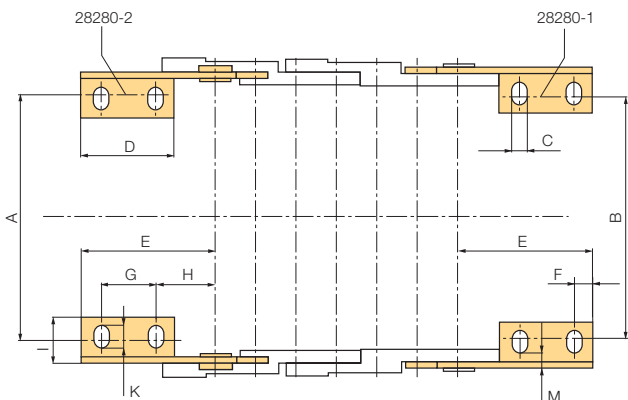

28280-12 = Full set, 4 parts, 2 parts with pin, 2 parts with bore
28280-1 = Mounting bracket with bore, 1 part left/right
28280-2 = Mounting bracket with pin, 1 part left/right

Strain relief package
► Strain Relief, Chapter 10

Click Here for
Specs &
CAD Files

A = B	C	D	E	F	G	H	I	K	M	
Bi - .79 (20)	.35 (9)	2.36 (60)	3.03 (77)	.47 (12)	1.38 (35)	1.18 (30)	1.04 (26.5)	.61 (15.5)	.28 (7)	in. (mm)



► Page 6.163



Order example

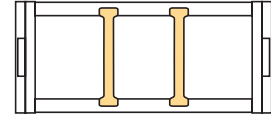
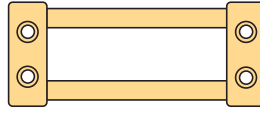
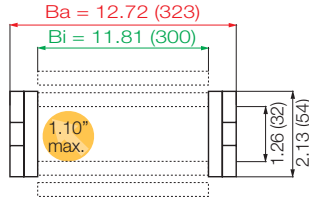

1. Chain selection:

2828-30-300-0



2. Mounting brackets:

282800-30-12P

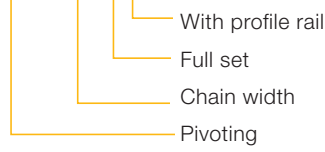

3. Interior separation:

2 separators, assembled every other link (part no. 281).
Alternative interior separation configuration according to design layout possible.

For 6.56 ft (2 m) chain, color black, with pivoting mounting brackets and integrated profile rail:
6.56 ft (2 m) 280-30-300-0 and 20800-30-12P and 4 Part. No. 281 assembled every other link

36 links — 5.49 links/ft (18 links/m)



Technical Data

Chain/Tube Width	Weight Per Link lbs (kg)			Weight lbs/ft (kg/m)		
	2828	2928	R7728	2828	2928	R7728
-05	.212 (0.096)	-	-	1.16 (1.73)	1.10 (1.64)	-
-06	.218 (0.099)	-	(1.79)	1.20 (1.67)	1.12 -	-
-07	.225 (0.102)	-	.333 (0.151)	1.24 (1.84)	1.14 (1.69)	1.83 (2.72)
-087	.236 (0.107)	-	-	1.30 (1.93)	1.16 (1.73)	-
-10	.247 (0.112)	-	.346 (0.157)	1.36 (2.02)	1.20 (1.78)	1.90 (2.83)
-11	.254 (0.115)	-	.359 (0.163)	1.40 (2.08)	1.22 (1.81)	1.98 (2.94)
-112	.262 (0.119)	-	-	1.44 (2.15)	1.24 (1.84)	-
-12	.269 (0.122)	-	.370 (0.168)	1.48 (2.20)	1.26 (1.87)	2.04 (3.03)
-137	.280 (0.127)	-	-	1.54 (2.29)	1.28 (1.91)	-
-15	.291 (0.132)	-	.390 (0.177)	1.60 (2.38)	1.32 (1.96)	2.14 (3.19)
-162	.298 (0.135)	-	-	1.64 (2.44)	1.34 (1.99)	-
-17	.306 (0.139)	-	.415 (0.188)	1.69 (2.51)	1.36 (2.02)	2.28 (3.39)
-18	.313 (0.142)	-	-	1.72 (2.56)	1.38 (2.05)	-
-187	.324 (0.147)	-	-	1.78 (2.65)	1.40 (2.09)	-
-20	.335 (0.152)	-	.439 (0.199)	1.84 (2.74)	1.44 (2.14)	2.41 (3.59)
-212	.350 (0.159)	-	-	1.93 (2.87)	1.48 (2.20)	-
-23	.357 (0.162)	-	-	1.96 (2.92)	1.49 (2.22)	-
-237	.373 (0.169)	-	-	2.05 (3.05)	1.54 (2.29)	-
-25	.379 (0.172)	-	.494 (0.224)	2.08 (3.10)	1.56 (2.32)	2.72 (4.04)
-262	.390 (0.177)	-	-	2.14 (3.19)	1.59 (2.36)	-
-28	.401 (0.182)	-	-	2.20 (3.28)	1.62 (2.41)	-
-29	.412 (0.187)	-	-	2.26 (3.37)	1.65 (2.45)	-
-30	.423 (0.192)	-	.542 (0.246)	2.33 (3.46)	1.68 (2.50)	2.98 (4.43)
-312	.439 (0.199)	-	-	2.41 (3.59)	1.72 (2.56)	-
-325	.441 (0.204)	-	-	2.47 (3.68)	1.75 (2.60)	-
-337	.461 (0.209)	-	-	2.53 (3.77)	1.78 (2.65)	-
-350	.472 (0.214)	-	-	2.59 (3.86)	1.81 (2.69)	-
-362	.483 (0.219)	-	-	2.65 (3.95)	1.84 (2.74)	-
-375	.494 (0.224)	-	-	2.72 (4.04)	1.88 (2.79)	-
-387	.503 (0.228)	-	-	2.76 (4.11)	1.90 (2.82)	-
-400	.512 (0.232)	-	-	2.81 (4.18)	1.92 (2.86)	-

Material	igumid G
Permitted temperature	-40°/+266°F (-40°/+130°C)
Gliding speed max.	16.4 ft/s (5 m/s)
Unsupported V max.	32.8 ft/s (10 m/s)
Flammability class	VDE 0304 IIC UL94 HB

- Details of material properties
- ▶ Design, Chapter 1

● Weight data tolerance: +/- 5%

PDF: www.igus.com/echainpdf.asp
 Specs/CAD/RFO: www.igus.com/echain.asp
 RoHS info: www.igus.com/RoHS.asp



Guide Troughs

Guide troughs are used with applications where the upper run of the Energy Chain® glides on the lower run. If using igus® steel guide troughs, the following components are required:

- Full travel length of guide trough
Part Number 98-30
- 1/2 travel length of glide bars
Part number 92-01
- Installation sets as end connectors
Part Number 93-50-XX

-XX indicates the length of the profile rail on which the guide trough is mounted. The values and part numbers are specified in the table on the left. The standard length of the trough components and glide bars is 6.56 ft (2 m.) The required overall length of the guide trough directly correlates to the length of travel.

Width of Crossbar
280-05-200-0

	B_{Pi}	Installation Part No.
-05	3.11 (79)	93-50-200
-06	3.82 (97)	93-50-225
-07	4.09 (104)	93-50-225
-087	4.57 (116)	93-50-225
-10	5.08 (129)	93-50-250
-11	5.39 (137)	93-50-250
-112	5.59 (142)	93-50-250
-12	6.06 (154)	93-50-275
-137	6.57 (167)	93-50-275
-15	7.05 (179)	93-50-300
-162	7.56 (192)	93-50-300
-17	7.76 (197)	93-50-325
-18	8.03 (204)	93-50-325
-187	8.54 (217)	93-50-325
-20	9.02 (229)	93-50-350
-212	9.53 (242)	93-50-350
-23	10.00 (254)	93-50-375
-237	10.51 (267)	93-50-375
-25	10.98 (279)	93-50-400
-262	11.50 (292)	93-50-400
-28	11.97 (304)	93-50-425
-29	12.48 (317)	93-50-425
-30	12.95 (329)	93-50-450
-312	13.46 (342)	93-50-450
-325	13.94 (354)	93-50-475
-337	14.45 (367)	93-50-475
-350	14.92 (379)	93-50-500
-362	15.43 (392)	93-50-500
-375	15.91 (404)	93-50-525
-387	16.42 (417)	93-50-525
-400	16.89 (429)	93-50-550

Example:

Length of travel 164 ft (50 m)
Center mounted
Required guide troughs:
164 ft (50 m) guide trough
82 ft (25 m) glide bar
= 25 sections of 6.56 ft (2 m) guide trough

Part No. 98-30
= 13 sections of 6.56 ft (2 m) glide bar

Part No. 92-01
Required number of installation sets:
= Number of guide trough components + 1
= 25 + 1 = 26

Part number of the installation sets
93-50-XXX
Example: 93-50-400 for 15.75 (400 mm) long profile rail.



Left: Guide trough with glide bars
Right: Guide troughs without glide bars



Installation sets as section connectors

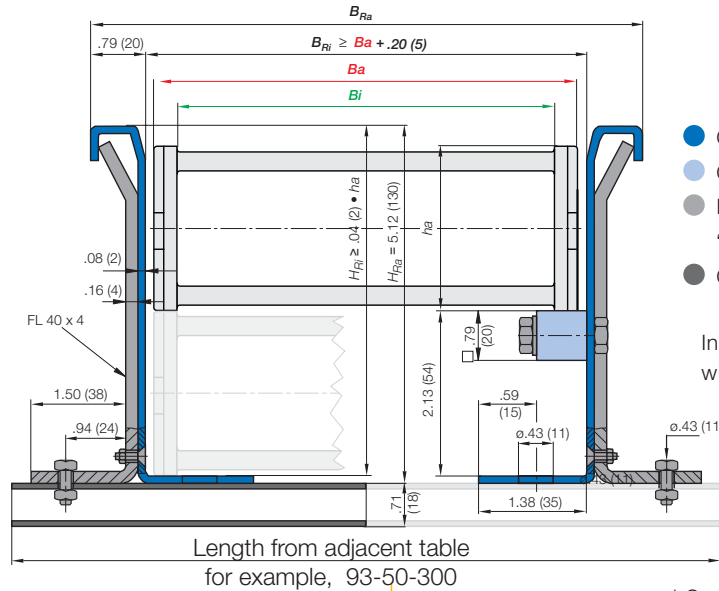

- Guide trough
- Glide bars
- Installation set "Basic"
- C-profile rail

Individual attachment without profile rail

* Specialized guide trough available upon request

Telephone 1-800-521-2747
Fax 1-401-438-7270

Internet: <http://www.igus.com>
email: sales@igus.com
QuickSpec: <http://www.igus.com/qs/echain.asp>

